

## SIMRAD SA50 Search and Rescue Transponder (SART)

The **SIMRAD SA50** Search & Rescue Transponder (**SART**) is a slim and light-weight emergency transponder, which can be deployed within minutes. The **SA50** can be both manually or automatically activated.

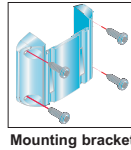

### 1. Installation

Using the supplied bulkhead bracket, mount the **SART** in a suitable and protected location, where it can be easily reached in the event of an emergency. The **SART** will simply clip onto the bracket provided.

The **SART** may also be pre-packed in the life raft, in which case the manufacturer will provide mounting instructions for use when the life raft is inflated.

#### IMPORTANT!

The **SA50** must not be installed within the main beam of the ship's radar. A compass-safe distance of at least 1m (3 ft) must be observed.

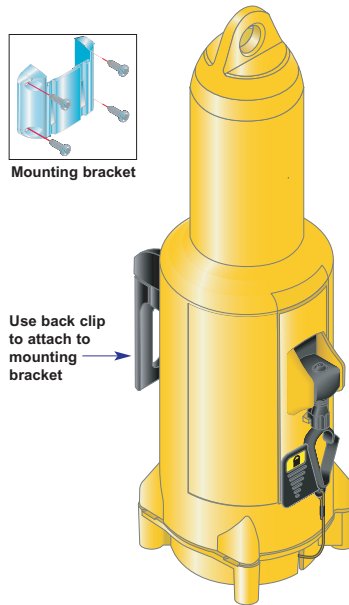

Fig. 1.1 - The **SIMRAD SA50**  
Search and Rescue Transponder (**SART**)

### 2. Activating the SART

In the event of an emergency remove the **SART** from its bracket and (1) flip the black plastic tab from left (LOCK) to right (UNLOCK). (2) To activate the **SART** remove the pin by pulling it downward.

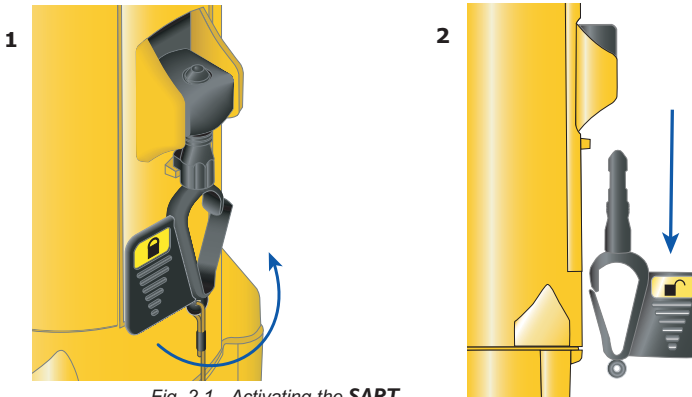

Fig. 2.1 - Activating the **SART**

Take the **SART** and the mounting pole (if available) to the life raft. When the life raft is inflated, EITHER

(1) unwind the lanyard (which is attached to the pin) and attach the **SART** to the life raft, OR

(2) open out the mounting pole (which will twist-lock into position) and mount the **SART** on the thinner end of the pole. Pass it through the aperture in the canopy and locate the bottom of the pole in the pocket provided. Secure the **SART** with the tapes provided on the life raft.

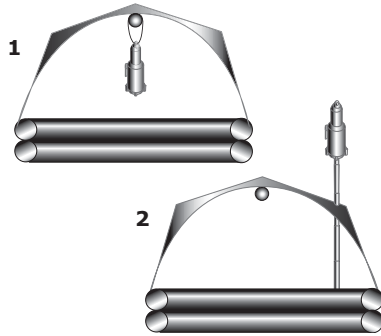

Fig. 2.2 - Attaching the **SART** to a life raft

### 3. Care and Maintenance

The **SART** will need very little maintenance between battery replacements. The batteries require replacement after five years (always check the label on the battery pack), or after use. The replacement date is shown on a label on the outside of the unit.

If the **SART** is stored in an exposed position, then regular cleaning is recommended. **DO NOT** use solvents on this product as this may damage the plastic components.

### 4. Testing the SART

As a minimum the **SART** should be tested annually to ensure correct performance.

- Remove the **SART** from its mounting and rotate the security tab to the UNLOCK position.
- Push the gray button down to the TEST position and hold it down until the test is completed.

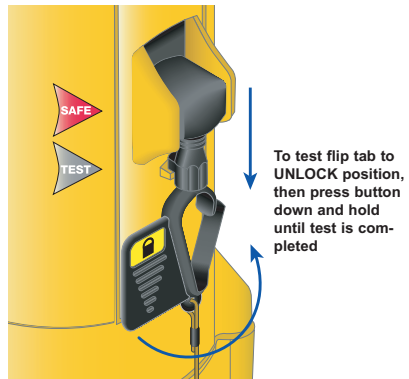

Fig. 3.1 - Testing the **SART**

- Check that the indicator on the **SART** is flashing. On the ship's X-band radar observe that the **SART** is displayed as blips, adjusting the radar's gain if necessary.

When testing is completed, return the gray button to the SAFE position and rotate the priming tab back to the LOCK position to secure the transponder. When testing **DO NOT** remove the pin.

**NOTE** —If the **SART** is inadvertently activated, it can be locked again by pressing down the activation button (to the SAFE position) and reinserting the pin.

For further information about the **SIMRAD** product range and services, please visit our website at: [www.simrad.com](http://www.simrad.com).

#### Disclaimer

The technical data, information and illustrations contained in this publication were to the best of our knowledge correct at the time of going to print. We reserve the right to change specifications, equipment, installation and maintenance instructions without notice as part of our policy of continuous development and improvement. No part of this publication may be reproduced, stored in a retrieval system or transmitted in any form, electronic or otherwise without prior permission from Simrad Ltd. No liability can be accepted for any inaccuracies or omissions in the publication, although every care has been taken to make it as complete and accurate as possible.